



## INSTALLATION & OPERATING GUIDE

For Technical Service, contact Bunn-O-Matic Corporation at 1-800-286-6070.

**Bunn-O-Matic Corporation**  
Post Office Box 3227, Springfield, Illinois 62708-3227  
Phone (217) 529-6601 | Fax (217) 529-6644

# BUNN-O-MATIC COMMERCIAL PRODUCT WARRANTY

Bunn-O-Matic Corp. ("BUNN") warrants equipment manufactured by it as follows:

- 1) All coffee and tea dispensers/servers, MCR/MCP/MCA single cup brewers, and BUNNlink® electronic circuit and/or control boards – 1 year parts and 1 year labor.
- 2) Product-specific warranties for Premia™, Crescendo®, Fast Cup®, Sure Immersion®, Sure Tamp® and others – 1 year parts and 1 year labor. Please visit [commercial.bunn.com/support/warranty-lookup](http://commercial.bunn.com/support/warranty-lookup) for further details.
- 3) All other equipment – 2 years parts and 1 year labor plus added warranties as specified below:
  - a) Electronic circuit and/or control boards – parts and labor for 3 years.
  - b) Compressors on refrigeration equipment – 5 years parts and 1 year labor.
  - c) Grinding burrs on coffee grinding equipment for 4 years or 40,000 pounds of coffee, whichever comes first.
- 4) For customers subscribed to BUNNlink®, BUNN reserves the right to periodically auto-push critical software updates that will enhance functionality or performance of the BUNN equipment, unless the customer requests advance notice of such software updates from BUNN in writing.

These warranty periods run from the date of installation. BUNN warrants that the equipment manufactured by it will be commercially free of defects in material and workmanship existing at the time of manufacture and appearing within the applicable warranty period. This warranty does not apply to any equipment, component or part that was not manufactured by BUNN or that, in BUNN's judgment, has been affected by misuse, neglect, alteration, improper installation or operation, improper maintenance or repair, non periodic cleaning and descaling, equipment failures related to poor water quality, damage or casualty. In addition, the warranty does not apply to replacement of items subject to normal wear with use including but not limited to user replaceable parts such as seals and gaskets. This warranty is conditioned on the Buyer 1) giving BUNN prompt notice of any claim to be made under this warranty by telephone at (217) 529-6601 or by writing to Post Office Box 3227, Springfield, Illinois 62708-3227; 2) if requested by BUNN, shipping the defective equipment prepaid to an authorized BUNN service location; and 3) receiving prior authorization from BUNN that the defective equipment is under warranty.

**THE FOREGOING WARRANTY IS EXCLUSIVE AND IS IN LIEU OF ANY OTHER WARRANTY, WRITTEN OR ORAL, EXPRESS OR IMPLIED, INCLUDING, BUT NOT LIMITED TO, ANY IMPLIED WARRANTY OF EITHER MERCHANTABILITY OR FITNESS FOR A PARTICULAR PURPOSE.** The agents, dealers or employees of BUNN are not authorized to make modifications to this warranty or to make additional warranties that are binding on BUNN. Accordingly, statements by such individuals, whether oral or written, do not constitute warranties and should not be relied upon.

If BUNN determines in its sole discretion that the equipment does not conform to the warranty, BUNN, at its exclusive option while the equipment is under warranty, shall either 1) provide at no charge replacement parts and/or labor (during the applicable parts and labor warranty periods specified above) to repair the defective components, provided that this repair is done by a BUNN Authorized Service Representative; or 2) shall replace the equipment or refund the purchase price for the equipment.

**THE BUYER'S REMEDY AGAINST BUNN FOR THE BREACH OF ANY OBLIGATION ARISING OUT OF THE SALE OF THIS EQUIPMENT, WHETHER DERIVED FROM WARRANTY OR OTHERWISE, SHALL BE LIMITED, AT BUNN'S SOLE OPTION AS SPECIFIED HEREIN, TO REPAIR, REPLACEMENT OR REFUND.**

In no event shall BUNN be liable for any other damage or loss, including, but not limited to, lost profits, lost sales, loss of use of equipment, claims of Buyer's customers, cost of capital, cost of down time, cost of substitute equipment, facilities or services, or any other special, incidental or consequential damages.

# CONTENTS

BUNN-O-MATIC COMMERCIAL PRODUCT WARRANTY .....	2
USER NOTICES .....	3
NORTH AMERICAN REQUIREMENTS .....	4
REFRIGERATED EQUIPMENT CLIMATE CLASSIFICATION .....	4
INITIAL SETUP .....	5
ELECTRICAL REQUIREMENTS .....	5
ELECTRICAL HOOK-UP .....	5
PLUMBING REQUIREMENTS .....	5
PLUMBING HOOKUP .....	6
INITIAL FILL .....	6
OPERATING CONTROLS .....	7
Refrigeration Switch .....	7
Program Switch .....	7
Rinse / Dispense / Sanitize Switch .....	7
Product Dispense Switch (Portion Membrane Switch) .....	8
Door Temperature Display .....	8
Error & Fault Code List .....	8
PRODUCT SETUP .....	9
Water Flow Rate Verification .....	9
Option 1 .....	9
Loading (Concentrates) & Priming .....	9
Option 2 .....	9
Setting Ratio / Brix Using Refractometer .....	11
Setting Ratio / Brix Using Total Dispense Method .....	11
Ratio Target Chart .....	12
Portion Control Adjustment (Cup Volume) .....	12
CLEANING & PREVENTIVE MAINTENANCE .....	13
Daily Cleaning .....	13
Weekly Cleaning .....	13
FUNCTION LIST .....	15
Circuit Board LED Indicators .....	15
SCHEMATIC DIAGRAMS .....	16
COOLANT .....	16
WIRING .....	16

## USER NOTICES

Carefully read and follow all notices on the equipment and in this manual. They were written for your protection. All notices are to be kept in good condition. Replace any unreadable or damaged labels.

**⚠ WARNING**

- ◆ Use only on a properly protected circuit capable of the rated load.
- ◆ Electrically ground the chassis.
- ◆ Follow national/local electrical codes.
- ◆ Do not use near combustibles.
- ◆ Do not deform plug or cord.

FAILURE TO COMPLY RISKS EQUIPMENT DAMAGE, FIRE OR SHOCK HAZARD.

READ THE ENTIRE OPERATING MANUAL BEFORE USING THIS PRODUCT

00986.0000M 10/14 ©1994 Bunn-O-Matic Corporation

00986.0000

As directed in the International Plumbing Code of the International Code Council and the Food Code Manual of the Food and Drug Administration (FDA), this equipment must be installed with adequate backflow prevention to comply with federal, state and local codes. For models installed outside the U.S.A., you must comply with the applicable Plumbing /Sanitation Code for your area.

00656.0001

CHARGE

Type R290, Amount 2.2 oz (62 gm)

Design Pressures:

High 255 psi (17.6 bar) (1.76 MPa)

Low 36 psi (2.5 bar) (0.25 MPa)

33461.0017

⚠ CAUTION

Propane (R-290)

**Risk of Fire or Explosion**

- Flammable Refrigerant Used.
- Dispose of Properly in Accordance with Federal or Local Regulations.

59203.0000



59205.0000

⚠ DANGER

Propane (R-290)

**Risk of Fire or Explosion**

- Dispose of Properly in Accordance with Federal or Local Regulations.
- Flammable Refrigerant Used.

59202.0000

⚠ WARNING

<p><b>Moving Parts.</b></p> <p>Do not operate unit with this panel removed.</p>	<p><b>Risk Of Electrical Shock.</b></p> <p>Disconnect power before servicing unit.</p>
---	--

27442.0000

## NORTH AMERICAN REQUIREMENTS

- This appliance must be installed in locations where it can be overseen by trained personnel.
- For proper operation, this appliance must be installed where the temperature is between 41°F to 95°F (5°C to 35°C).
- Appliance shall not be tilted more than 10° for safe operation.
- An electrician must provide electrical service as specified in conformance with all local and national codes.
- This appliance must not be cleaned by pressure washer.
- This appliance can be used by persons aged from 18 years and above if they have been given supervision or instruction concerning use of the appliance in a safe way and if they understand the hazards involved.
- Keep the appliance and its cord out of reach of children aged less than 18 years.
- Appliances can be used by persons 18 years and above with reduced physical, sensory or mental capabilities or lack of experience and knowledge if they have been given supervision or instruction concerning use of the appliance in a safe way and understand the hazards involved.
- Children under the age of 18 years should be supervised to ensure they do not play with the appliance.
- If the power cord is ever damaged, it must be replaced by the manufacturer or authorized service personnel with a special cord available from the manufacturer or its authorized service personnel in order to avoid a hazard.
- Machine must not be immersed for cleaning.
- Cleaning and user maintenance shall not be made by children unless they are older than 18 years and supervised.
- This appliance is intended for commercial use in applications such as:
  - staff kitchen areas in shops, offices and other working environments
  - by clients in hotel and motel lobbies and other similar types of environments
- Access to the service areas permitted by Authorized Service personnel only.
- Do not store explosive substances such as aerosol cans with a flammable propellant in this equipment.
- Any component parts shall be replaced with like components so as to minimize the risk of possible ignition due to incorrect parts.
- Equipment is to be installed in accordance with the Safety Standard for Refrigeration Systems, ANSI/ASHRAE 15.
- Precautions shall be taken to avoid excessive vibration or pulsation.
- WARNING: Keep any required ventilation openings clear of obstruction
- WARNING: Do not use electrical equipment inside the food/ice storage compartments unless they are of the type recommended by the manufacturer.
- WARNING: Keep clear of obstruction all ventilation openings in the equipment enclosure or in the structure for building-in.
- WARNING
  - Do not use means to accelerate the defrosting process or to clean, other than those recommended by the manufacturer.
  - The equipment shall be stored in a room without continuously operating ignition sources (for example: open flames, an operating gas equipment, or an operating electric heater).
  - Do not pierce or burn.
  - Be aware that refrigerants may not contain an odor.

## REFRIGERATED EQUIPMENT CLIMATE CLASSIFICATION

Commercial refrigerated equipment is designed to work under certain climate conditions that are rated by climate classes. This equipment is classified as test room climate class 4, which indicates a maximum temperature limit of 30 degrees C (86 degrees F) and a maximum relative humidity limit of 55%.

## INITIAL SETUP

**CAUTION:** The dispenser is very heavy! Use care when lifting or moving it. Use at least two people to lift or move the dispenser. Place dispenser on a sturdy counter or shelf able to support at least 150 lbs. (68 kg). This dispenser is designed for indoor use only.

Set the dispenser on the counter where it will be used. This dispenser requires a minimum of 4 inches (102 mm) of air clearance at the rear and side. For optimum performance, **do not** let warm air from surrounding machines blow on the dispenser. Leave some space so the dispenser can be moved for cleaning.

## ELECTRICAL REQUIREMENTS

**CAUTION:** The dispenser must be disconnected from the power source until specified in Electrical Hook-Up.

The 120V rated dispensers have an attached cord set and require a 2-wire, grounded, individual branch circuit rated 120 volts ac, 15 amp, single phase, 60Hz. The mating connector must be a NEMA 5-15R.

The 220-230V rated dispenser has an attached cord set and requires an attachment plug cap rated at least 230 volts ac, 15 amp. The attachment plug cap must meet with applicable national/local electrical codes.

**Refer to the data plate for exact electrical requirements.**

## ELECTRICAL HOOK-UP

**CAUTION:** Improper electrical installation will damage electronic components.

1. An electrician must provide electrical service as specified.
2. Using a voltmeter, check the voltage and color coding of each conductor at the electrical source.
3. Confirm that the compressor switch near the main control board is in the OFF position.
4. Connect the dispenser to the power source.
5. If plumbing is to be hooked up later, be sure the dispenser is disconnected from the power source. If plumbing has been hooked up, the dispenser is ready for setup.

## PLUMBING REQUIREMENTS

This dispenser must be connected to a chilled water supply line system with a 50 psi minimum dynamic operating pressure. This water source must be capable of producing a minimum flow rate of 8 fluid ounces (236 milliliters) per second. BUNN also requires a pressure gauge at the inlet of the dispenser for diagnostic purposes. A shut off valve should be installed in the line before the dispenser. The main water inlet adapter fitting is a 1/2" (12.7 mm) MFL connection.

**NOTE:** At least 18 inches (457 mm) of an FDA approved flexible beverage tubing, such as reinforced braided polyethylene, before the dispenser will facilitate movement to clean the counter-top.

**As directed in the International Plumbing Code of the International Code Council and the Food Code Manual of the Food and Drug Administration (FDA), this equipment must be installed with adequate back flow prevention to comply with federal, state and local codes. For models installed outside the U.S.A., you must comply with the applicable Plumbing/Sanitation Code for your area.**

## PLUMBING HOOKUP

The plumbing connection is located on the rear of the dispenser. A 1/2" (12.7 mm) male flare adapter fitting is supplied, installed on the rear of the dispenser (Fig.1).

NOTE: BUNN requires a pressure gauge at the inlet of the dispenser for diagnostic purposes. Accessory Part Number: 57524.1000 - Pressure Gauge Assembly, 1/2" Inlet (Fig. 2)

NOTE: Water pipe connections and fixtures directly connected to a potable water supply shall be sized, installed and maintained in accordance with federal, state and local codes.

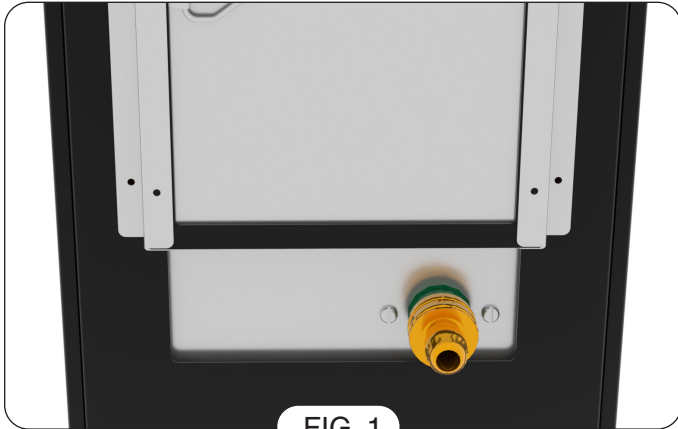

FIG. 1  
Plumbing Connection - 1/2" MFL

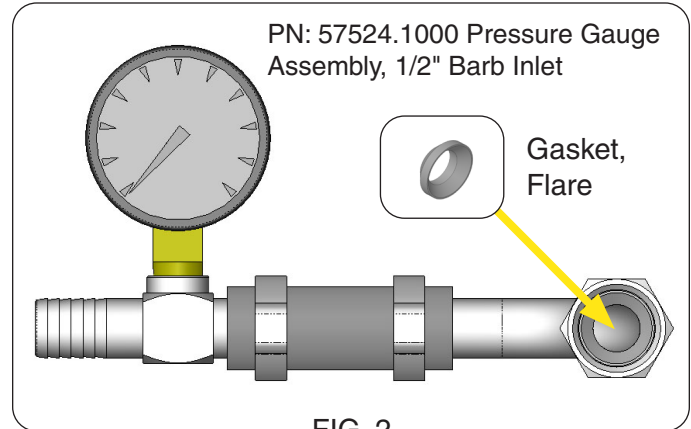

FIG. 2  
Plumbing Connection - 1/2" Barb to 1/2" FFL

## INITIAL FILL

This dispenser is equipped with an automatic water bath fill system. Do not apply power to the dispenser until all plumbing connections are complete and water is supplied. With water supplied, applying power to the dispenser will cause the bath to automatically be filled.

NOTE: The program switch does need to be in the OFF position for automatic bath fill system to operate.

1. Check water level in the sight gauge. Once the water stabilizes (level) in the sight gauge "T" fitting, extra water may trickle down the overflow tube into the drip tray. The compressor switch can be turned ON (Fig.3).
2. It will take several hours to create the ice bank required for full dispenser performance. During this time, some further trickling from the water bath is expected due to expansion caused by ice bank formation (Fig. 4). The dispenser may be readied for use as described in Loading, Priming and Adjustment.

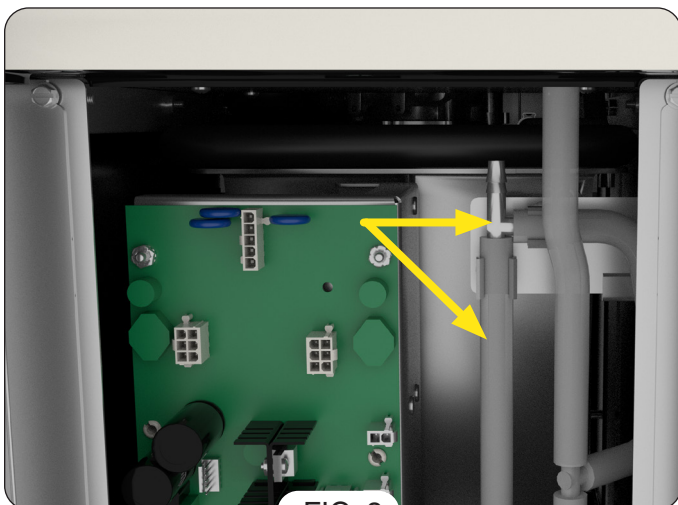

FIG. 3  
Sight Gauge Tube

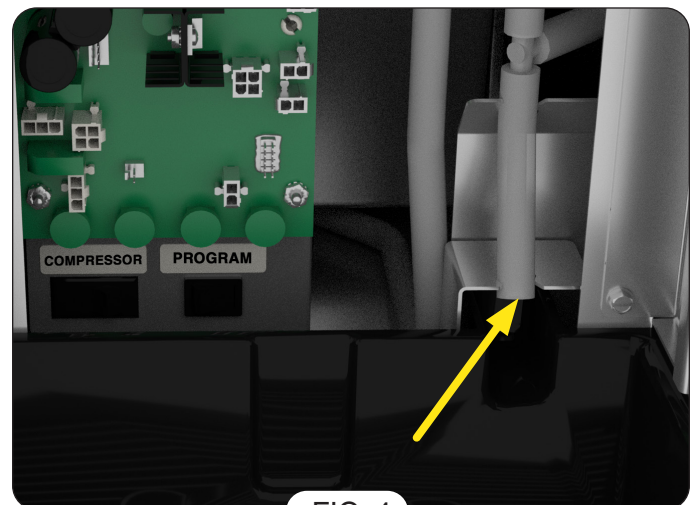
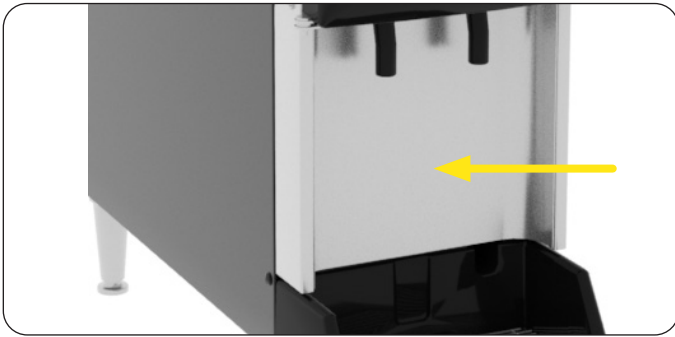

FIG. 4  
Overflow Tube

# OPERATING CONTROLS

## Refrigeration Switch

Remove lower splash panel. The refrigeration (compressor) switch is located on the Electrical Panel below the Circuit Board (Fig.5). This switch controls power to the relay contacts for the compressor and condenser fan motor.



Lower Splash Panel

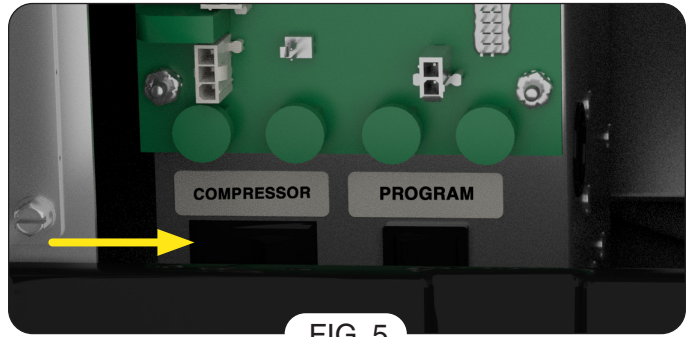
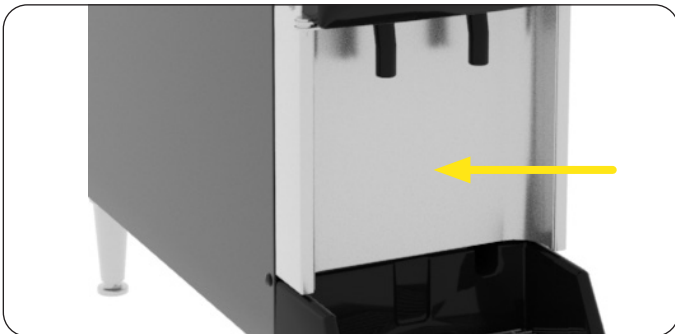

FIG. 5  
Compressor Switch

## Program Switch

Remove lower splash panel. The program switch is located below the main control board next to the compressor switch. The switch is used to enter a program test mode. The program mode can be used to test 3 second dispense of water only for "Water Flow Rate Verification" or 3 second dispense of water and concentrate (Fig. 6).



Lower Splash Panel

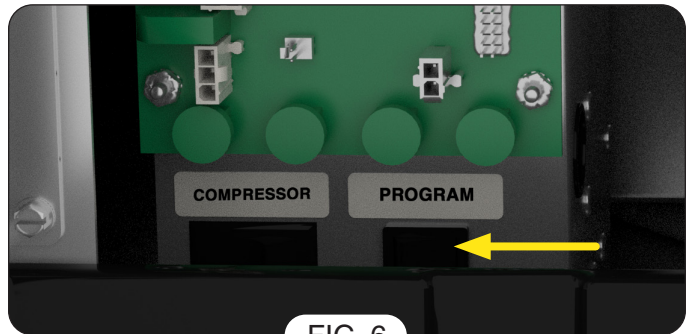

FIG. 6  
Program Switch

## Rinse / Dispense / Sanitize Switch

Open cabinet door. The switch is located at the top right on the backside of the cabinet door. The switch is used to select rinse, dispense, and sanitize modes (Fig. 7).



Cabinet Door



FIG. 7  
Rinse / Dispense / Sanitize Switch

## OPERATING CONTROLS

*continued from previous page*

### Product Dispense Switch (Portion Membrane Switch)

Product Dispense Switch Membrane

Factory Setting:

Sm-3 sec, Md Sm-6 sec, Md Lg-9 sec and Lg-12 sec.

- Momentarily pressing and releasing one of the portion switches will initiate a timed dispense.
- Each station has four different timed dispenses which are preset at the factory.

NOTE: Refer to "Portion Control Adjustment" section for procedures.

- Momentarily pressing any switch during a timed dispense will cancel/stop the flow.



**Product Dispense Switches**

### Door Temperature Display

The dispenser is equipped with a refrigerated compartment digital temperature display on the door. This will show the cooling compartment temperature in degrees Fahrenheit (Fig. 8).

This display is also used to communicate Error & Fault Codes.

#### ERROR & FAULT CODE LIST

- fil - Err = When the water bath is filling but doesn't reach the float switch within a certain fill time, the refill circuit will stop filling and the display will show "fil - Err".
- Fault 1 = Bath temperature sensor shorted
- Fault 2 = Bath temperature sensor open
- Fault 3 = Not used
- Fault 4 = Cabinet temperature sensor open
- Fault 5 = Left concentrate motor stalled
- Fault 6 = Right concentrate motor stalled.

NOTE: All error and faults can be cleared with the rinse / dispense / sanitize switch inside the door.

Simply set the switch to sanitize, then back to dispense.



**FIG. 8**

**Door Display**

## PRODUCT SETUP

Two methods are available to operate the dispenser 3 sec. dispense flow test to verify water flow rate and sustainable dynamic 50 psig water pressure. Option 2 is the easier method without having to remove the lower splash panel to access program switch.

### Water Flow Rate Verification

#### OPTION 1

1. Place the Program switch in the ON position.
2. Place a measuring container under the dispense nozzle, press and release the DISPENSE button 3 times.
3. Record the total ounces/ML dispensed. Repeat 3 second dispense test minimum 3 times to check flow rate for accuracy.
4. Target dispense volume is 8.4 – 9.3 ounces (250 – 275ml.)
5. Water flow rate should be checked running one dispense station, then running both dispense stations at the same time. While dispensing, confirm the supply water pressure to the dispenser does not drop below 50 psig (dynamic flow reading).

NOTE: If water pressure is inconsistent or drops below the required 50 psig dynamic pressure, the water pressure issue must be corrected to ensure the required water flow rate to the dispenser.

6. Place the Program switch back into the OFF position.

#### OPTION 2

1. Place the Rinse /Dispense/Sanitize switch in the Rinse position.
2. Place a graduated cylinder under the dispense nozzle.
3. Press/release any dispense button at that station. The dispenser will run a timed 3 second dispense of water only. Repeat 3 second dispense test minimum 3 times to check flow rate for accuracy.
4. Target dispense volume is 8.4 – 9.3 ounces (250 – 275ml.)
5. Water flow rate should be checked running one dispense station, then running both dispense stations at the same time. While dispensing, confirm the supply water pressure to the dispenser does not drop below 50 psig (dynamic flow reading).

NOTE: If water pressure is inconsistent or drops below the required 50 psig dynamic pressure, the water pressure issue must be corrected to ensure the required water flow rate to the dispenser.

6. Place the switch back into the Dispense position.

### Loading (Concentrates) & Priming

\*Priming the product is only required during installation. For loading product without priming, see steps 5-7.

1. Shut off water.
2. Open the dispenser door and remove concentrate holding trays.
3. Locate the left and right dispense valves. Remove the front screw to release the retaining bracket.

NOTE: the right dispense valve will require you to gently pull the drip tray out of the way of the screw. (fig 10)

4. Pull the concentrate fitting from the dispense valve(s).

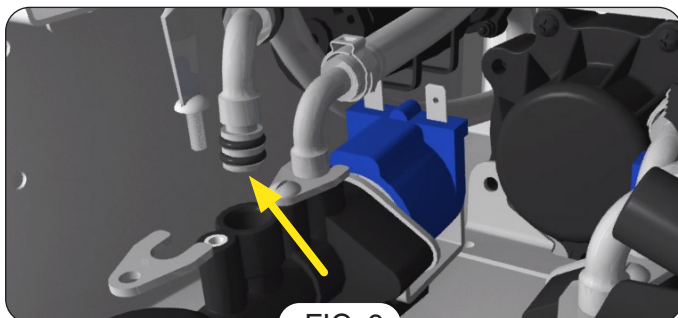

FIG. 9  
Parts Removed: Left Dispense Valve

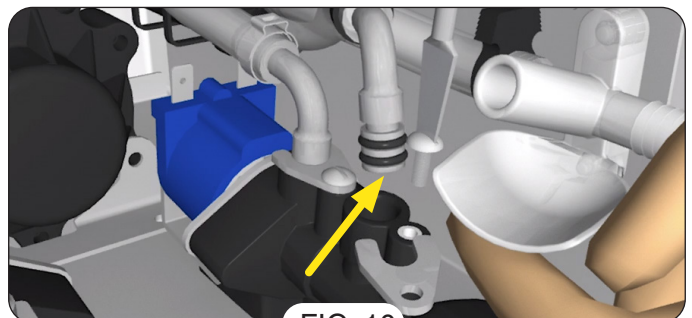

FIG. 10  
Parts Removed: Right Dispense Valve

## PRODUCT SETUP

*continued from previous page*

5. Thoroughly mix the thawed concentrate in the bag by gently handling and maneuvering the bag around to mix concentrate before placing in dispenser cabinet.
6. Place the concentrate bag in the tray with the connection tube going through the large hole in the bottom of the tray. Use the holders in the corner of the tray to capture the corner of the bag. This will support the bag for better evacuation of concentrate while dispensing.

NOTE: Before loading the lower shelf with product, make sure the left dispense station is primed with product concentrate (steps 7-10).

7. Slide tray into dispenser shelf starting with the front of the tray lifted higher than the rear of the tray. Once in the dispenser, open the cap on the fitting and connect to the appropriate fitting in the dispenser.
8. Place a large container under the appropriate dispense nozzle.
9. Momentarily press a dispense switch for the side that is being primed with concentrate. You will know when the tube is primed when product concentrate reaches the pump head.

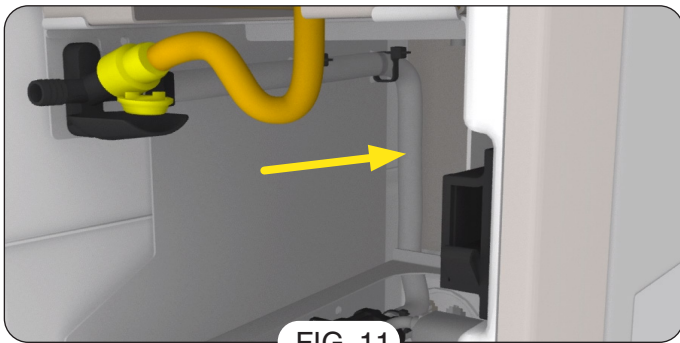

FIG. 11  
Left Station Not Primed

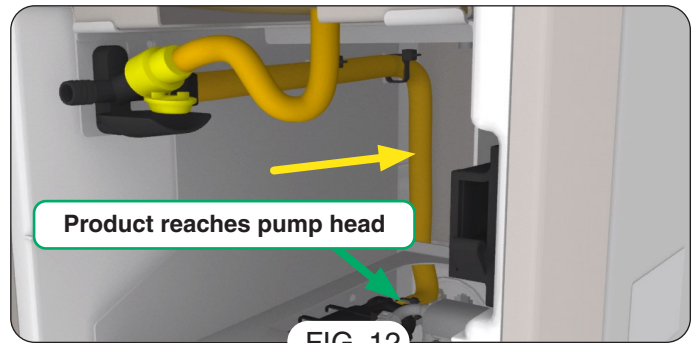

FIG. 12  
Left Station Primed

10. Reinsert the concentrate fitting into the dispense valve as soon as product concentrate reaches the pump head. Secure the fitting with the retaining bracket and screw.

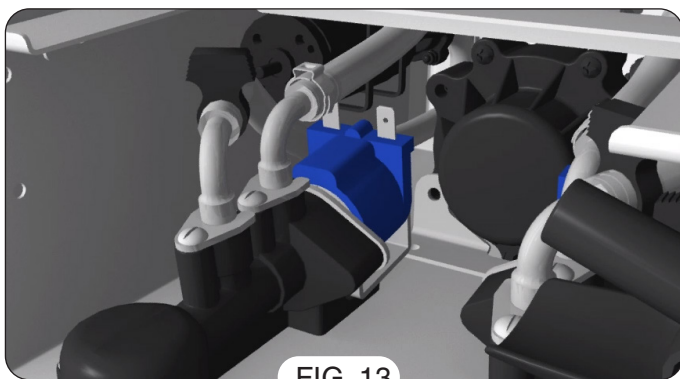

FIG. 13  
Left Dispense Valve with Secured Fittings

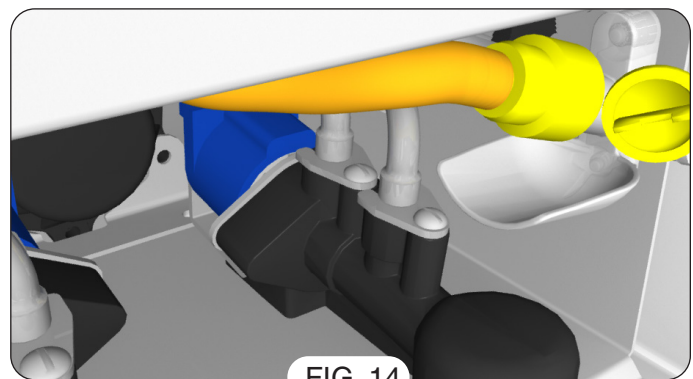

FIG. 14  
Right Dispense Valve with Secured Fittings

11. Close the dispenser door.

## PRODUCT SETUP

### Setting Ratio / Brix Using Refractometer

1. Load concentrate bag in dispenser. Dispense a few times to confirm the system has been primed and product is dispensing.
2. Disconnect or unplug dispenser. Remove the drip tray and splash panel to access control board, then replace drip tray.
3. Locate the adjustment knobs on the lower portion of the main control board. Use the two left most knobs to make pump speed adjustments. Left most being station #1 (left side dispense) and left center being station #2 (right side dispense).
4. Always start with the adjustment knobs in about the 12 o'clock position. Turn the adjustment knob clockwise to increase concentrate pump speed and counterclockwise to decrease speed.
5. Reconnect dispenser to power. Place a clean cup on the drip tray under the dispense nozzle.
6. Select the corresponding dispense station and depress the appropriate dispense size to start the timed dispense.
7. Use a refractometer to check the brix. Stir the product in the cup, then collect a sample from the middle of the cup and place on the refractometer lens.
8. Using the corresponding adjustment knob to make the appropriate small adjustment to the pump speed. Repeat steps 1 thru 7 until ratio/brix setting is achieved. Verify ratio/brix setting by collecting 2-3 consecutive samples.
9. Disconnect power or unplug dispenser. Reinstall splash panel, drip tray and reconnect to power.

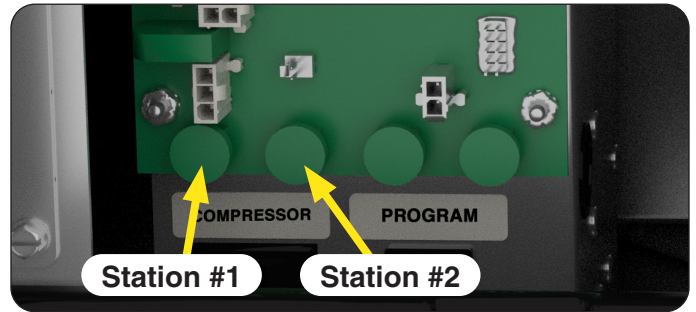

### Setting Ratio / Brix Using Total Dispense Method

1. Load concentrate bag in dispenser. Dispense a few times to confirm the system has been primed and product is dispensing.
2. Disconnect or unplug dispenser. Remove the drip tray and splash panel to access control board, then replace drip tray.
3. Locate the adjustment knobs on the lower portion of the main control board. Use the two left most knobs to make pump speed adjustments. Left most being station #1 (left side dispense) and left center being station #2 (right side dispense).
4. Always start with the adjustment knobs in about the 12 o'clock position. Turn the adjustment knob clockwise to increase concentrate pump speed and counterclockwise to decrease speed.
5. Locate the program switch near the main control board. Turn the program switch on.
6. Reconnect dispenser to power. Place a clean measuring cylinder on the drip tray under the dispense nozzle.
7. Press/release the corresponding station portion dispense button 3 times to initiate a 3 second water only dispense. Measure and record the volume dispensed.
8. Place a clean measuring cylinder on the drip tray under the dispense nozzle. Press/release the corresponding station portion dispense button 6 times to initiate a 3 second water and concentrate dispense. Measure and record the volume dispensed.
9. Refer to the **Ratio Target Chart** to determine the target volume based on water volume measured previously and the target product ratio. If the total volume is correct, set up is complete. If total volume is too low or too high, adjust the concentrate pump speed knob in small increments until the target volume is achieved.
10. Disconnect power or unplug dispenser. Reinstall splash panel, drip tray and reconnect to power.

## PRODUCT SETUP

### Ratio Target Chart

	Ratio Target
<b>3 Sec. Water Dispense (In Ounces)</b>	<b>5 + 1</b>
8.11	9.73
8.28	9.94
8.45	10.14
8.62	10.34
8.79	10.55
8.96	10.75
9.12	10.94
9.29	11.15
9.46	11.35

	Ratio Target
<b>3 Sec. Water Dispense In Milliliters</b>	<b>5 + 1</b>
240.0	288.0
245.0	294.0
250.0	300.0
255.0	306.0
260.0	312.0
265.0	318.0
270.0	324.0
275.0	330.0
280.0	336.0

### Portion Control Adjustment (Cup Volume)

The following steps will guide you through the portion size (volume) adjustment process for this option.

NOTE: Water flow check and brix/ratio should be set-up prior to setting portion sizes.

1. Unplug dispenser from power source.
2. Remove drip tray and splash panel from the front of the machine then replace the drip tray.
3. Set the Program Switch (near main control board) to the ON position.
4. Re-connect or plug-in the dispenser to power source.
5. Press and hold any two dispense switches for 3 seconds. Display will read "Por".
6. Place a container under the desired dispense nozzle to measure the portion size.
7. Press and hold the desired dispense switch to dispense product until the desired amount of product is achieved. (Maximum dispense time is 150 seconds). Repeat this on all portion sizes as desired.
8. Set the Program Switch (near main control board) to the OFF position.
9. Place a container under the dispense nozzle(s) and press and release the portion dispense switch to confirm that the portion size is set correctly. Repeat steps 1-6 if any changes are needed.
10. Replace splash panel.

NOTE: The portion control dispense can be cancelled during a dispense by pressing the dispense button again.

NOTE: When setting portion sizes, if the button is pressed/released in under 1.0 second, that dispense button will operate like a push & hold dispense.

# CLEANING & PREVENTIVE MAINTENANCE

## Daily Cleaning

### Supplies

- 1 packet of KAY-5® Sanitizer/Cleaner solution
- KAY® Peroxide Multi Surface Cleaner & Disinfectant Solution (3N1)
- 1 KAY-5 Sanitizer/Cleaner squeeze bottle
- 2 empty small containers
- Small bristled brush
- Clean, sanitizer-soaked towel

### Procedure

NOTE: Clean the nozzles and interior/exterior of machine daily.

1. Open dispenser door and press “RINSE”.
2. Remove the drip tray and take to the 3-compartment sink to wash, rinse and sanitize. Allow to air dry.
3. With the drip tray removed, place 1 empty container underneath the dispense nozzles.
4. On the front door, select a dispense station button to start the rinse cycle.
5. Repeat the rinse cycle again for the other side of the dispense station.
6. Open dispenser door and select “DISPENSE”.
7. Prepare 2.5 gallons of KAY-5 Sanitizer/Cleaner solution. Mix 1 packet of KAY-5 Sanitizer/Cleaner solution with 2.5 gallons of lukewarm water (85-105 F) for a 100ppm solution.
8. Fill 2 small empty containers and a squeeze bottle with KAY-5 Sanitizer/Cleaner solution and set aside.
9. Remove both nozzles from the dispenser. Twist then pull down to remove.
10. Place the nozzles into one of the small containers filled with KAY-5 Sanitizer/Cleaner solution.
11. With the nozzles removed, dip the small brush into the small container of KAY-5 Sanitizer/Cleaner solution and then scrub the interior of the dispense valves.
12. With the KAY-5 squeeze bottle, squeeze KAY-5 Sanitizer/Cleaner solution vigorously into the dispense valve to sanitize. Repeat for both valves.
13. With the small brush, scrub the interior and exterior of the nozzles and o-rings in the container.
14. Remove the nozzles from the cleaning container and place into the other container to sanitize for 1 minute.
15. Wash hands before reinstalling the clean nozzles.
16. Remove nozzles from solution and replace on the dispenser.
17. Wipe up spills inside the machine with Peroxide Multi Surface Cleaner and Disinfectant (3N1) solution and a clean, sanitizer-soaked towel.
18. Spray a clean, sanitizer-soaked towel with Peroxide Multi Surface Cleaner and Disinfectant (3N1) solution and wipe down the exterior of the machine.

## Weekly Cleaning

### Supplies

- KAY-5 Sanitizer/Cleaner Solution
- 2 cleaning tubes provided with BUNN machine
- KAY Peroxide Multi Surface Cleaner & Disinfectant Solution (3N1)
- 2 empty small containers
- Small-bristled brush
- Clean, sanitizer-soaked towels

# CLEANING & PREVENTIVE MAINTENANCE

*continued from previous page*

## **Procedure - Clean In Place**

NOTE: Clean and sanitize the interior juice lines.

1. Remove the juice concentrate bags and store in a separate refrigerator during cleaning.
2. Remove the drip tray and bag holders and take to the 3-compartment sink to wash, rinse and sanitize. Allow to air dry.
3. With the drip tray removed, place 1 empty container underneath the dispense nozzles.
4. Prepare 2.5 gallons of KAY-5 Sanitizer/Cleaner solution. Mix 1 packet of KAY-5 Sanitizer/Cleaner with 2.5 gallons of lukewarm (85-105 F) for a 100 ppm solution.
5. Pour some of the KAY-5 solution into another small empty container and set aside.  
NOTE: This solution will be used for cleaning and sanitizing the removed nozzles.
6. Remove both nozzles from the dispenser. Remove both o-rings from each nozzle.
7. Place the nozzles and o-rings into the small container of KAY-5 solution.
8. With the nozzles removed, dip the small brush into the small container of KAY-5 Sanitizer/Cleaner solution and then scrub the interior of the dispense valves.
9. With a small brush, scrub the interior and exterior of the nozzles and o-rings.
10. Wash hands before reinstalling the clean nozzles.
11. Replace clean nozzles.
12. Place the open end of the cleaning tubes into the 2.5 gallon solution of KAY-5 Sanitizer/Cleaner. Connect the other end of the cleaning tubes into the inlet adaptors.
13. Select "SANITIZE" using the switch on the inside of the door.
14. Press and hold any dispense station button for 5 seconds on the front of the door.
15. Allow the automatic sanitizing process to begin with both sides cleaning and dispensing at the same time.
  - a. 1 minute continuous dispensing to clean
  - b. 5 minute soak
  - c. 1 minute continuous dispense to sanitize
16. When the cycle is complete, remove the cleaning tubes.
17. Spray all areas of the interior machine (include the inlet adaptors) with KAY Peroxide Multi Surface Cleaner and Disinfectant Solution (3N1) and wipe with a clean, sanitizer-soaked towel. Spray again with KAY SolidSense Sanitizer solution to sanitize. Allow to air dry.
18. Spray a clean, sanitizer-soaked towel with Peroxide Multi Surface Cleaner and Disinfectant Solution and wipe down the exterior of the machine.
19. Replace the clean drip tray and bag holders into the machine.
20. Reinstall the juice concentrate.
21. Select "DISPENSE" using the switch on the inside of the dispense door.
22. At each station, press the small serving size twice to purge out the cleaner solution then discard. Make sure both dispense stations have been flushed out.

## **Monthly Cleaning**

### **Condenser Coils and Filter**

1. Removable filter on the rear panel of the dispenser can be cleaned in warm soapy water.
2. Use a soft bristle brush to clean the buildup of dirt in the condenser.

# FUNCTION LIST

## Circuit Board LED Indicators

LED #	LED Color	Illuminates
1 Bath	Red	When bath temperature is above 34 degrees F.  Flashes slowly when compressor is in a 6 minute delay period.  Open bath thermistor circuit will flash #1 and #2 LED's 1 time every 3 seconds. The compressor will not run under this condition.  Open bath thermistor circuit will flash #1 and #2 LED's 2 time every 3 seconds. The compressor will not run under this condition.
2 Bath	Green	When bath temperature is below 34 degrees F.
3	Green	When the compressor should be ON.
4 Cabinet	Red	When the cabinet temperature is above 50 degrees F.  Flashes slowly when cabinet temperature exceeds 50 degrees F for 4 hours. Dispense functions are locked out under this condition. The display will read "Loc". - To clear this fault, open door, select "sanitize", then select "dispense".  Flashes rapidly if dispense is attempted in lockout condition.  Open cabinet thermistor circuit will flash #4 and #5 LED's 1 time every 3 seconds.  Shorted cabinet thermistor will turn #4 and #5 LED's on steady. *This mode disables the cabinet low temperature lockout fault.
5 Cabinet	Green	When cabinet temperature is below 50 degrees F.

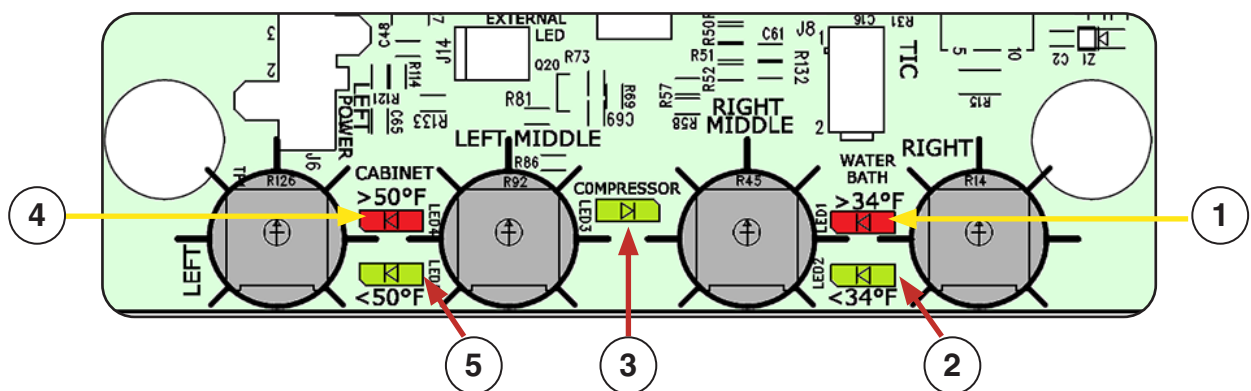

Control Board LED Indicators

# SCHEMATIC DIAGRAMS

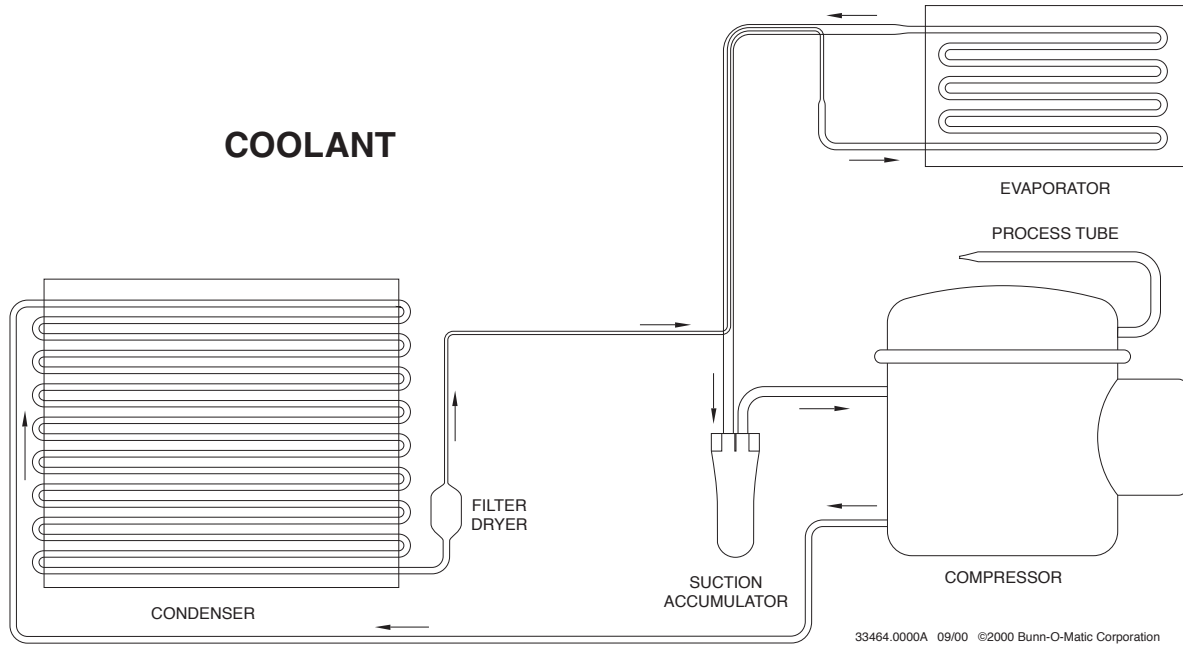

## WIRING JDF-2X FF (FAST FLOW)

